

● SPECIFICATION



2 雷射線 : 雷射線 規格 (IEC / EN60825-1 / 2014) Ⅱ 雷射線 規格 & lt1 ⅡmW
 635 : 雷射線 規格 Ⅱnm \ 510nm
 3 ± : 雷射線 規格 mm / 10m
 雷射線 規格: mm 2mm / 10m
 3 ± : 雷射線 規格 mm / 10m
 雷射線 3 : 雷射線 規格
 雷射線 規格: H110 ° / V180 雷射線
 1 ± ° 4 : 雷射線 規格 / 雷射線 規格 °
 25 : (Ⅱ / Ⅱ) 雷射線 規格 M / 15M \ 50M / 20M
 雷射線 12 雷射線 : 雷射線 規格
 雷射線 × 2 : 雷射線 AA Ⅱ > 1500mA (雷射線 規格)
 雷射線 IP: IP54 Ⅱ 雷射線 規格 Ⅱ 雷射線 規格 Ⅱ Ⅱ Ⅱ
 50 Ⅱ - °C 10- : 雷射線 規格 Ⅱ Ⅱ Ⅱ °C
 70 Ⅱ - °C 20- : 雷射線 規格 Ⅱ Ⅱ Ⅱ °C
 9.3 : 雷射線 x6.4 × 8 3.7) Ⅱ "x2.5" x3.1 ")

● PRODUCT PICTURES





VARIOUS KINDS OF FIXING METHOD





POWER ON

Short press the power key or slide locking switch to turn the laser tool ON.

OFF

Lock the pendulum before short press the power button to turn the laser tool OFF.



self-leveling mode

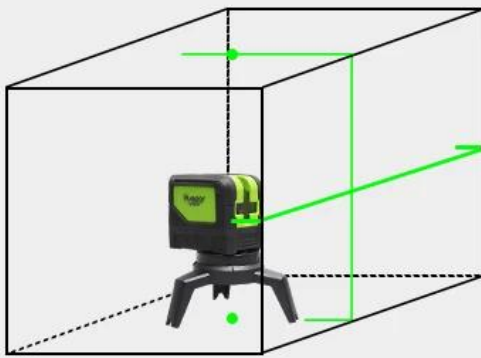

Self-level Available



Within 4 Degree

$\leq \pm 4^\circ$



Pendulum Unlocked

manual mode



Maintain The 90° Angles



Blinks Every 3 Seconds



Pendulum Locked

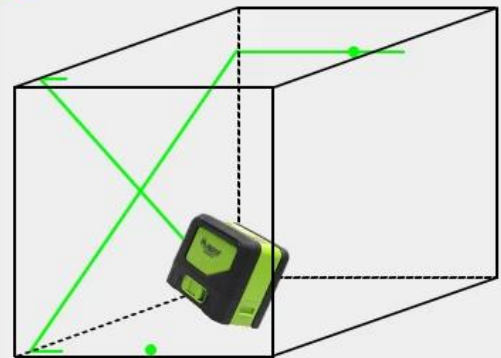



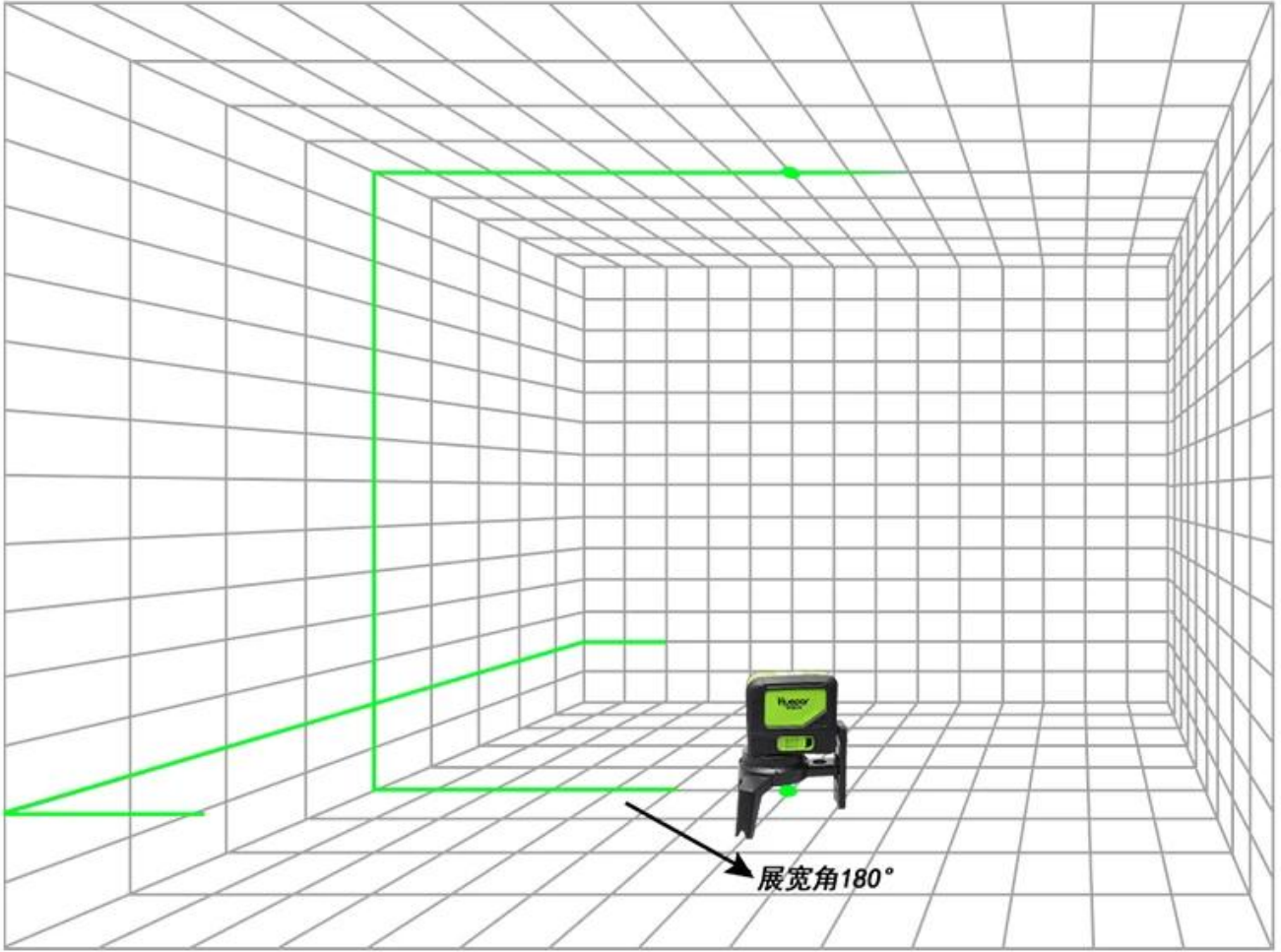



● PACKAGE INCLUDE

XEAST®



● TERMS OF TRADE

XEAST®

1) باي بال ، موني جرام ، ويسترن يونيون ، ، T / T ، L / C شروط الدفع: نحن نقبل .
30% ودائع وغيرها 70% الرصيد قبل الشحن.

2) شروط الشحن:

ذلك يعتمد على كمية طلب العملاء وطلباتكم الخاصة

3) سيتم فحص العناصر بعناية قبل الشحن ، وسوف نقوم بتحديث حالة التسليم في الوقت المناسب بعد إرسال البضاعة

● COMPANY INFORMATIONS

XEAST®



SALES TEAM



WOKRSHOP

