

Rango de autonivelación de 4 ± 1 grado

Carcasa robusta sobre moldeada

Ultra Bright Laser Beams permite todas las aplicaciones posibles

IP54 - Resistente al agua y al polvo

Simplifique las tareas de diseño y aumente la productividad

El mecanismo de cierre centralizado ayuda a proteger los elementos internos

Nivel láser parámetro:

Nivel láser XE-903:

Longitud de onda del láser: 510nm ~ 530nm

Grado impermeable: IP54

Exactitud total: ± 3 mm / 10m

Precisión ortotrópica: $90^\circ \pm 30''$

Rango de nivelación: $4^\circ \pm 1^\circ$

Ancho de línea: 2mm / 10m.

Distancia de trabajo (línea): 40 m, hasta 50 m con láser revelador
enchufe: **EU plus**

Potencia de trabajo: **Batería de Litio**

Tiempo de trabajo: 6 horas con todos los rayos láser encendidos.

Clase de láser: II

función de inclinación: **SÍ**

Rango de temperatura de funcionamiento: $-10^\circ\text{C} - +50^\circ\text{C}$

Rango de temperatura de almacenamiento: $-20^\circ\text{C} - +70^\circ\text{C}$

Especificaciones del receptor láser:

PWM: 1: 1

Frecuencia: 10 KHz (PWM y frecuencia combinadas, los láseres de línea pueden funcionar con el receptor láser LR-6RG)

Pantalla: Indicador LED de tres lados

Precisión de nivelación: ± 1.5 mm ($\pm 1/17$ pulg.)

Ancho de la ventana de recepción del láser: 20 mm (4/5 pulg.)

Altura de la ventana de recepción láser: 20 mm (4/5 pulg.)

Distancia de trabajo: 50m (200ft)

Tiempo de funcionamiento: 70 horas

Apagado automático: (sin señal detectada) 8 min

Fuente de alimentación: batería seca 1 * 9V

Rango de temperatura de funcionamiento: -10 °C a + 50

Rango de temperatura de almacenamiento: -25 °C a + 70

Dimensión (LxWxH): 140.5mm × 60mm × 35mm (5.5 x 2.5 x 1.5 pulgadas)

Peso: 143 g

● **PRODUCT PICTURES**

XEAST®









laser window •
on-off key/pulse-function button •



• battery charge interface

1/4 thread interface •
Battery compartment •
lithium battery •







*Slower
beeping
tone
signals*



*Fast
beeping
tone
signals*



*Beeping
tone
signals*

self-leveling mode

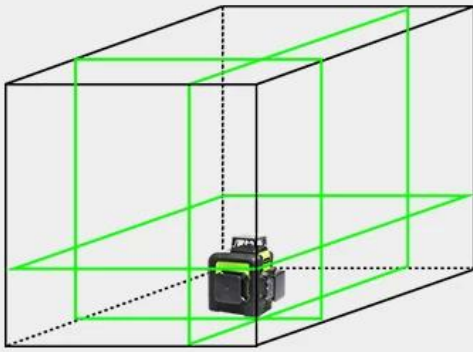

Self-level Available



Within 4 Degree

$\leq \pm 4^\circ$



Pendulum Unlocked



manual mode



Maintain The 90° Angles



Blinks Every 3 Seconds



Pendulum Locked

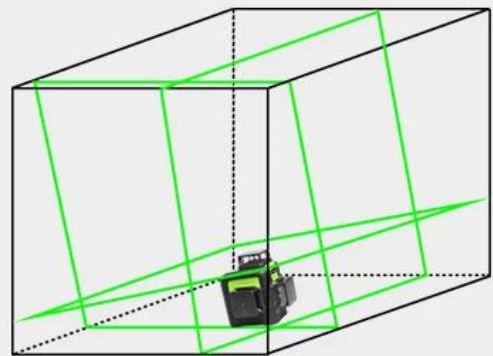

POWER ON

Short press the power key or slide locking switch to turn the laser tool ON.

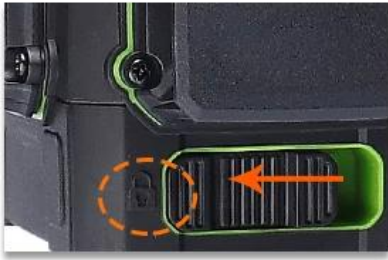

OFF

Lock the pendulum before short press the power button to turn the laser tool OFF.

1: After power on, short press the power switch once a time, the laser tool will project horizontal line, vertical line and cross line in turn.

2: After power on, long press the power key, when the blue light is on, the pulse mode is on.



GERMANY OSRAM GREEN LASER TECHNOLOGY



More brighter to ordinary green beam and red beam

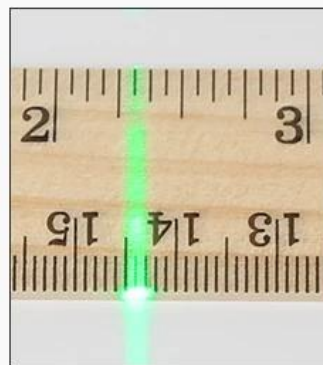

Germany osram green beam

ordinary green beam

ordinary red beam

VARIOUS KINDS OF FIXING METHOD



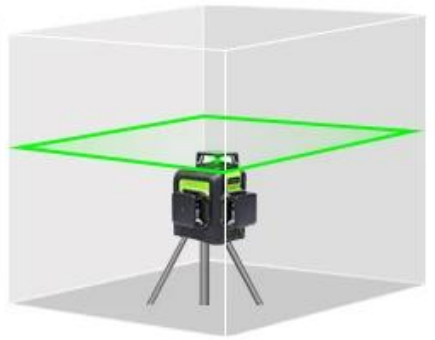
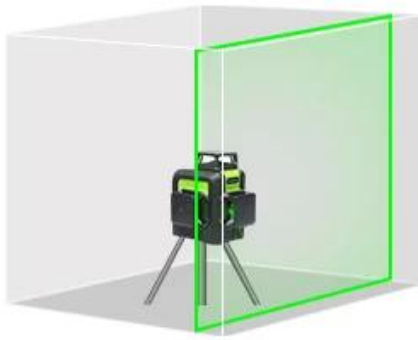
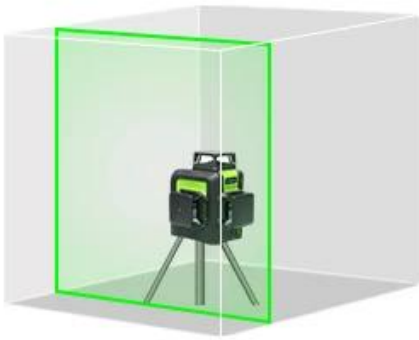
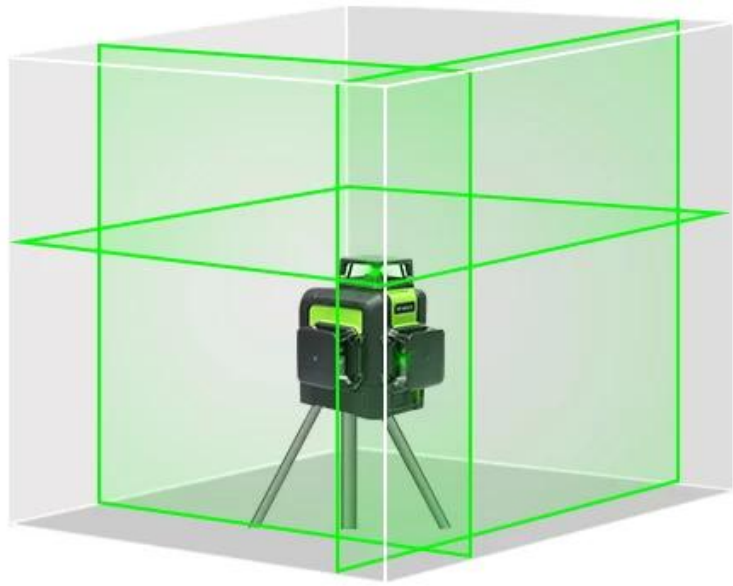

Three line switching function

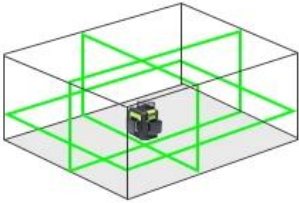
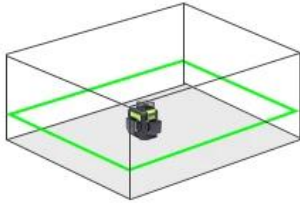
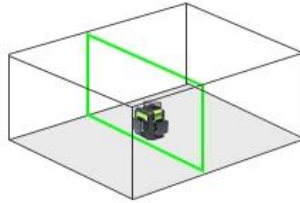
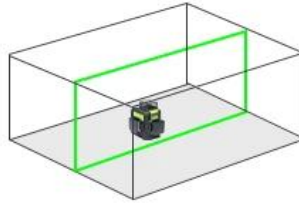
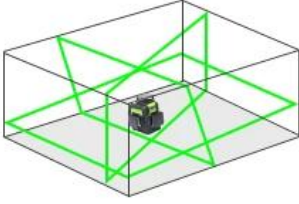
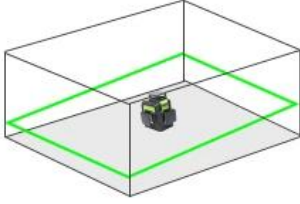
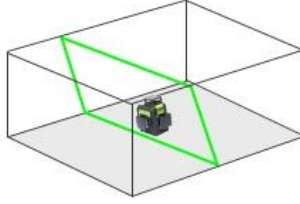
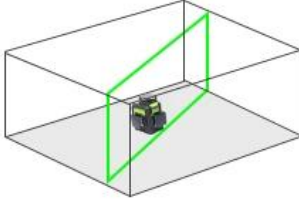
Horizontal and vertical lines	Horizontal	vertical lines	vertical lines
			
Horizontal and vertical lines	Horizontal	vertical lines	vertical lines
			



***Please turn on
Pulse Mode of the
Laser level
before using
the reciever***



● **PACKAGE INCLUDE**

XEAST®



● TERMS OF TRADE

1). Términos del pago: Aceptamos T / T, L / C, Paypal, MoneyGram y Western Union.

Depósito del 30% y otro saldo del 70% antes del envío.

2). Términos de envío:

Depende de la cantidad de pedido de los clientes y de su solicitud especial. A menudo adoptamos Express (DHL, TNT, UPS, FEDEX, EMS, SPSR, 139 express y así sucesivamente), LCL, FCL

3). Los artículos se revisarán cuidadosamente antes del envío, y actualizaremos el estado de entrega oportunamente después de que se envíen las mercancías.

● COMPANY INFORMATIONS



SALES TEAM



WOKRSHOP

