

Plage de mise à niveau automatique de 4 ± 1 degrés

Boîtier robuste surmoulé

Les faisceaux laser ultra-lumineux permettent toutes les applications possibles

IP54 - Étanche à l'eau et à la poussière

Simplifier les tâches de mise en page et augmenter la productivité

Le mécanisme de verrouillage centralisé protège les éléments internes

Niveau laser paramètre:

Niveau laser XE-903:

Longueur d'onde laser: 510nm ~ 530nm

Grade étanche: IP54

Précision générale: $\pm 3\text{mm} / 10\text{m}$

Précision orthotropique: $90^\circ \pm 30''$

Plage de nivellement: $4^\circ \pm 1^\circ$

Largeur de trait: 2mm / 10m.

Distance de travail (ligne): 40 m, jusqu'à 50 m avec un récepteur laser

fiche d'alimentation: **UE plus**

Puissance de travail: **batterie au lithium**

Temps de travail: 6 heures avec tous les faisceaux laser

Classe de laser: II

fonction d'inclinaison: **OUI**

Plage de température de fonctionnement: -10°C à $+50^\circ\text{C}$

Plage de température de stockage: -20°C à $+70^\circ\text{C}$

Spécifications du récepteur laser:

PWM: 1: 1

Fréquence: 10KHz (PWM et fréquence correspondantes, les lasers de ligne peuvent fonctionner avec le récepteur laser LR-6RG)

Affichage: Indicateur LED à trois côtés

Précision de nivellement: $\pm 1.5\text{mm}$ ($\pm 1/17$ In.)

Largeur de la fenêtre de réception laser: 20 mm (4/5 po)

Hauteur de la fenêtre de réception laser: 20 mm (4/5 po)

Distance de travail: 50m

Durée de fonctionnement: 70 heures

Mise hors tension automatique: (sans signal détecté) 8 min

Source d'alimentation: pile sèche 1 * 9V

Température de fonctionnement: -10 à + 50

Plage de température de stockage: -25 à + 70

Dimension (L xlxh): 140,5 mm × 60 mm × 35 mm (5,5 x 2,5 x 1,5 pouces)

Poids: 143g

● **PRODUCT PICTURES**

XEAST®









laser window •
on-off key/pulse-function button •



• battery charge interface

1/4 thread interface •
Battery compartment •
lithium battery •







*Slower
beeping
tone
signals*



*Fast
beeping
tone
signals*



*Beeping
tone
signals*

self-leveling mode

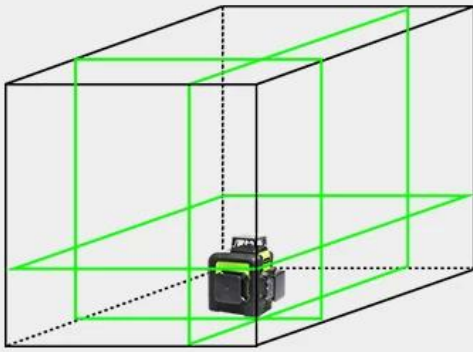

Self-level Available



Within 4 Degree

$\leq \pm 4^\circ$



Pendulum Unlocked



Maintain The 90° Angles



Blinks Every 3 Seconds



Pendulum Locked

manual mode

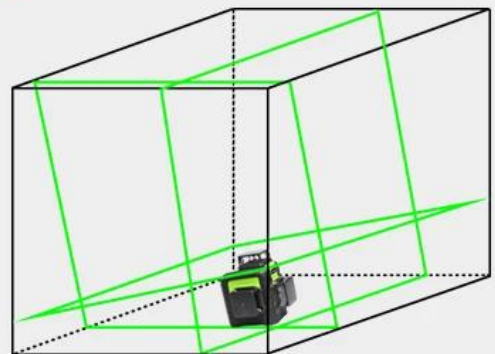

POWER ON

Short press the power key or slide locking switch to turn the laser tool ON.

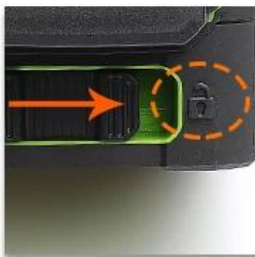

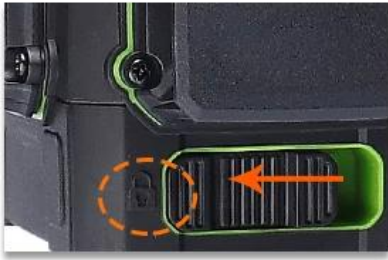

OFF

Lock the pendulum before short press the power button to turn the laser tool OFF.

1: After power on, short press the power switch once a time, the laser tool will project horizontal line, vertical line and cross line in turn.

2: After power on, long press the power key, when the blue light is on, the pulse mode is on.



GERMANY OSRAM GREEN LASER TECHNOLOGY



More brighter to ordinary green beam and red beam

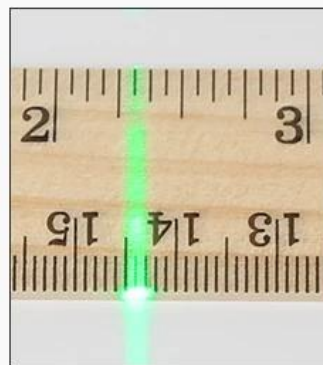

Germany osram green beam

ordinary green beam

ordinary red beam

VARIOUS KINDS OF FIXING METHOD



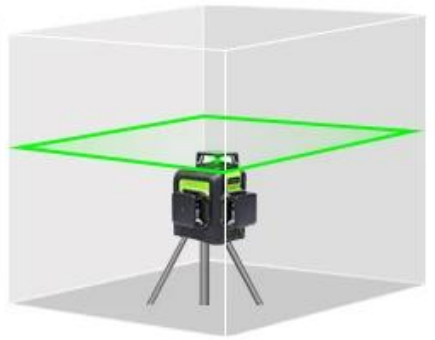
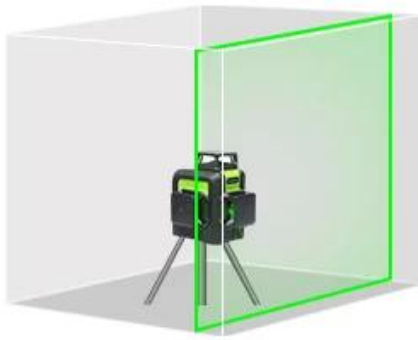
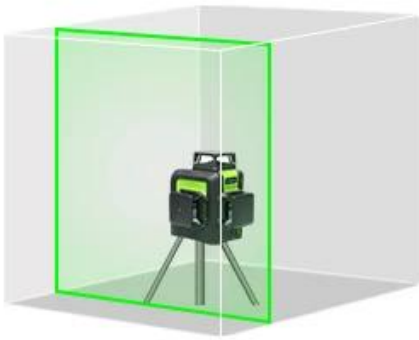
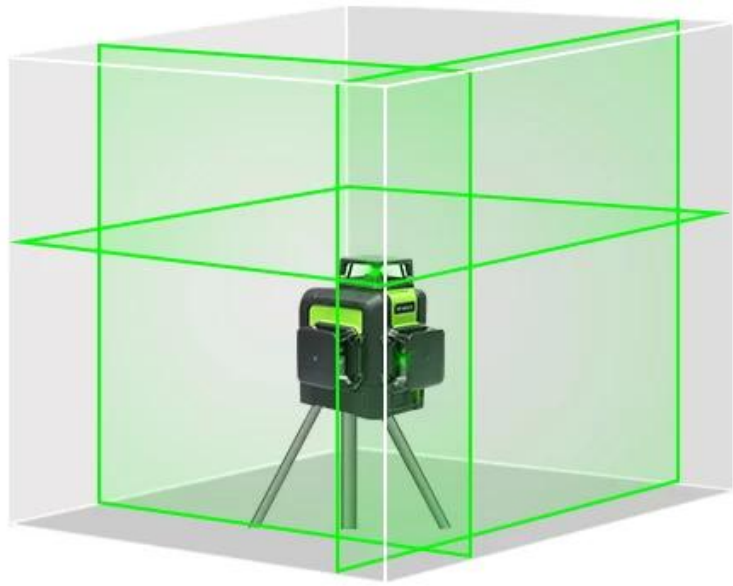

Three line switching function

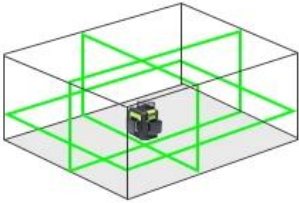
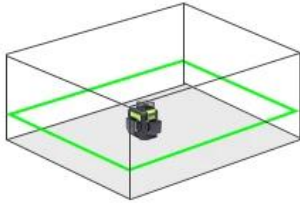
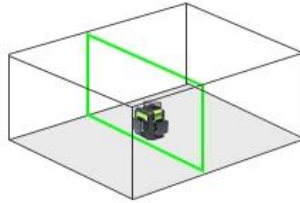
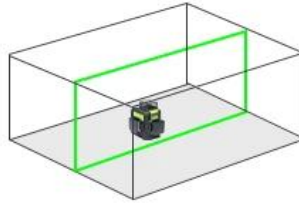
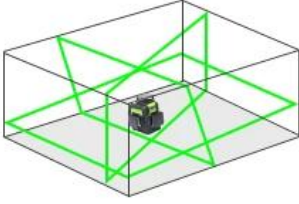
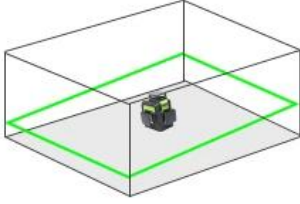
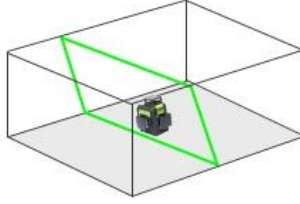
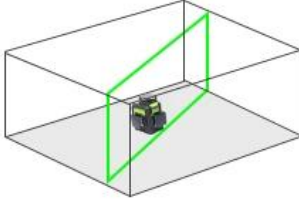
Horizontal and vertical lines	Horizontal	vertical lines	vertical lines
			
Horizontal and vertical lines	Horizontal	vertical lines	vertical lines
			



***Please turn on
Pulse Mode of the
Laser level
before using
the reciever***



● PACKAGE INCLUDE

XEAST®



● TERMS OF TRADE

1). Conditions de paiement: Nous acceptons T / T, L / C, Paypal, MoneyGram et Western Union.
Dépôt de 30% et autre solde de 70% avant expédition.

2) Conditions de livraison:

Cela dépend de la quantité commandée par les clients et de votre demande spéciale. Nous adoptons Express (DHL, TNT, UPS, FEDEX, SME, SPSR, 139 express, etc.), LCL, FCL

3) Les articles seront soigneusement vérifiés avant expédition, et nous mettrons à jour le statut de livraison après l'envoi des marchandises.

● COMPANY INFORMATION



SALES TEAM



XEAST®
Your Testing Partner



WOKRSHOP

