

Gamma di autolivellamento di 4 ± 1 grado

Robusto alloggiamento sovrastampato

I raggi laser ultra brillanti consentono tutte le possibili applicazioni

IP54 - Impermeabile e antipolvere

Semplificare le attività di layout e aumentare la produttività

Il meccanismo di chiusura centrale aiuta a proteggere gli interni

Livello laser parametro:

Livello laser XE-903:

Lunghezza d'onda del laser: 510nm ~ 530nm

Grado impermeabile: IP54

Precisione complessiva: ± 3 mm / 10m

Precisione ortotropica: $90^\circ \pm 30''$

Campo di livellamento: $4^\circ \pm 1^\circ$

Larghezza della linea: 2mm / 10m.

Distanza di lavoro (linea): 40 m, fino a 50 m con ricevitore laser

Spina di alimentazione: **EU plus**

Potenza di lavoro: **batteria al litio**

Orario di lavoro: 6 ore con tutti i raggi laser accesi

Classe laser: II

funzione di inclinazione: **SÌ**

Intervallo di temperatura di funzionamento: $-10^\circ\text{C} - +50^\circ\text{C}$

Temperatura di stoccaggio: $-20^\circ\text{C} - +70^\circ\text{C}$

Specifiche del ricevitore laser:

PWM: 1: 1

Frequenza: 10 KHz (Matched PWM e frequenza, i laser Line possono funzionare con LR-6RG Laser Receiver)

Display: display indicatore LED a tre lati

Precisione di livellamento: $\pm 1,5$ mm ($\pm 1/17$ pollici)

Larghezza finestra di ricezione laser: 20 mm (4/5 pollici)

Altezza finestra di ricezione laser: 20 mm (4/5 pollici)

Distanza di lavoro: 50m (200ft)

Tempo di funzionamento: 70 ore

Spegnimento automatico: (senza segnale rilevato) 8 min

Alimentazione: 1 batteria a secco da 9V

Intervallo di temperatura operativa: da -10 °C a + 50 °C

Intervallo di temperatura di stoccaggio: da -25 °C a + 70 °C

Dimensione (LxWxH): 140,5 mm × 60 mm × 35 mm (5,5 x 2,5 x 1,5 pollici)

Peso: 143 g

● **PRODUCT PICTURES**

XEAST®









laser window •
on-off key/pulse-function button •



• battery charge interface

1/4 thread interface •
Battery compartment •
lithium battery •





*Slower
beeping
tone
signals*



*Fast
beeping
tone
signals*



*Beeping
tone
signals*

self-leveling mode

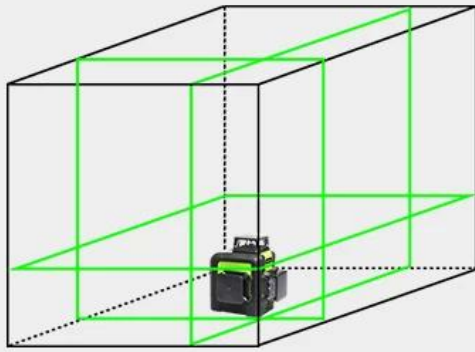

Self-level Available



Within 4 Degree

$\leq \pm 4^\circ$



Pendulum Unlocked



manual mode



Maintain The 90° Angles



Blinks Every 3 Seconds



Pendulum Locked

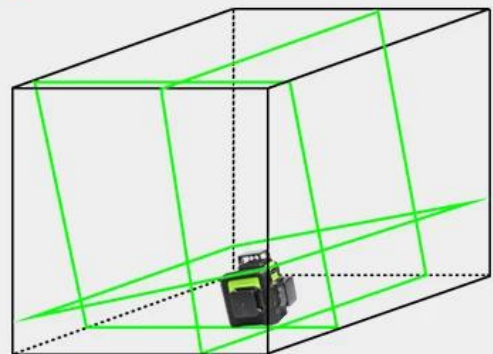

POWER ON

Short press the power key or slide locking switch to turn the laser tool ON.

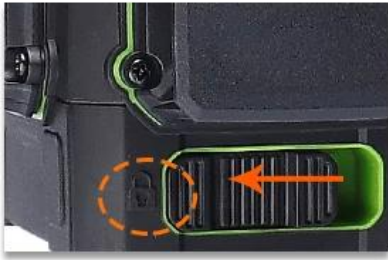

OFF

Lock the pendulum before short press the power button to turn the laser tool OFF.

1: After power on, short press the power switch once a time, the laser tool will project horizontal line, vertical line and cross line in turn.

2: After power on, long press the power key, when the blue light is on, the pulse mode is on.



GERMANY OSRAM GREEN LASER TECHNOLOGY



More brighter to ordinary green beam and red beam

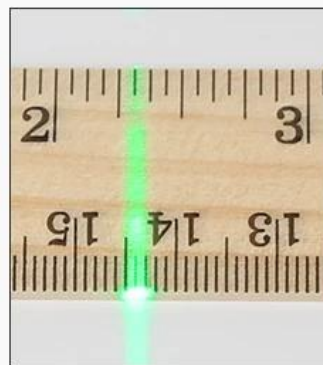

Germany osram green beam

ordinary green beam

ordinary red beam

VARIOUS KINDS OF FIXING METHOD



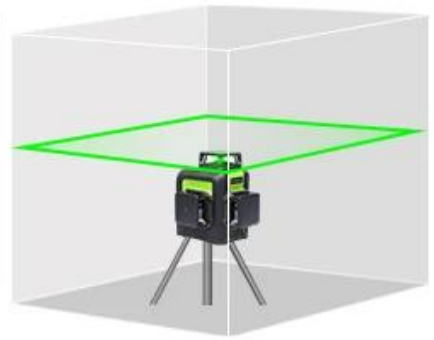
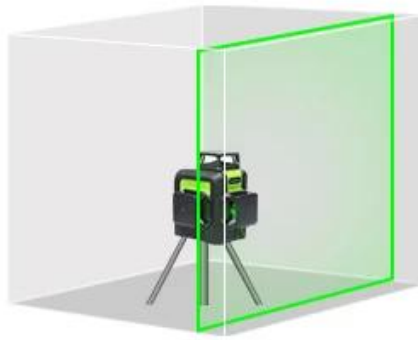
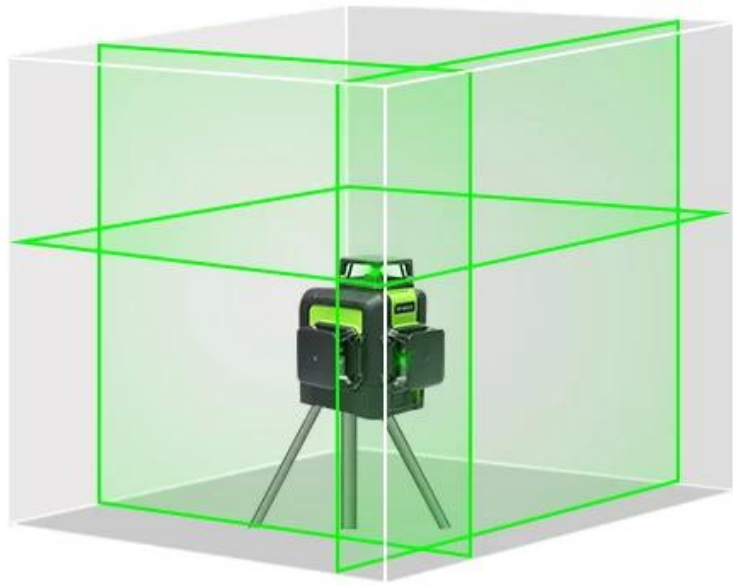

Three line switching function

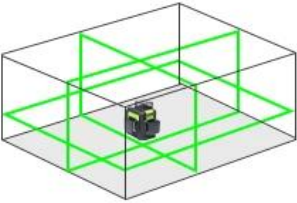
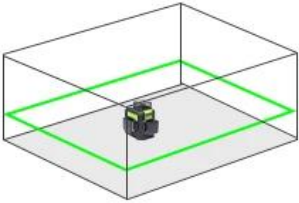
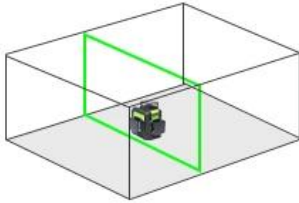
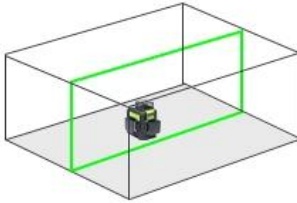
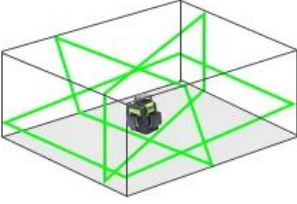
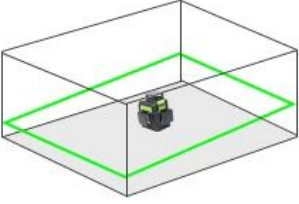
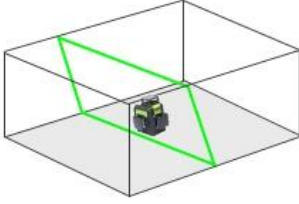
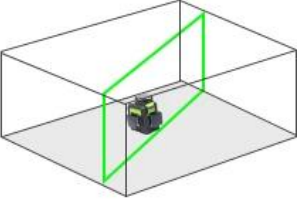
Horizontal and vertical lines	Horizontal	vertical lines	vertical lines
			
Horizontal and vertical lines	Horizontal	vertical lines	vertical lines
			



***Please turn on
Pulse Mode of the
Laser level
before using
the reciever***



● PACKAGE INCLUDE

XEAST[®]



● TERMS OF TRADE



1). Termini di pagamento: accettiamo T / T, L / C, Paypal, MoneyGram e Western Union.

Deposito del 30% e altri 70% saldo prima della spedizione.

2). Termini di spedizione:

Dipende dalla quantità di ordine dei clienti e dalla richiesta speciale. Noi adottiamo Express (DHL, TNT, UPS, FEDEX, EMS, SPSR, 139 express e così via), LCL, FCL

3). Gli articoli saranno controllati attentamente prima della spedizione e aggiorneremo lo stato della consegna in tempo utile dopo l'invio delle merci.

● COMPANY INFORMATIONS





SALES TEAM



WOKRSHOP

