

● SPECIFICATION



雷射等級: 2 (IEC / EN60825-1 / 2014), 雷射等級 < 1mW
 雷射波長: 635nm \ 510nm
 雷射光斑直徑: ± 3mm / 10m
 雷射光斑直徑: ± 2mm / 10m
 雷射光斑直徑: ± 3mm / 10m
 雷射線數: 3 雷射線
 雷射線角度: H110 ° / V180 °
 雷射線角度 / 雷射線角度: 4 ° ± 1 °
 雷射線距離 (雷射 / 雷射): 25m / 15m \ 50m / 20m
 雷射線數量: 雷射 12 雷射線
 雷射線電壓: 雷射線 AA 2 雷射線, > 1500mA (雷射線)
 雷射線 IP: IP54, 雷射線, 雷射線雷射線雷射線, 雷射線雷射線雷射線雷射線
 雷射線溫度: -10 °C - 50 °C
 雷射線溫度: -20 °C - 70 °C
 雷射線尺寸: 9.3x6.4x8cm (3.7" x2.5" x3.1")

● PRODUCT PICTURES





VARIOUS KINDS OF FIXING METHOD





POWER ON

Short press the power key or slide locking switch to turn the laser tool ON.

OFF

Lock the pendulum before short press the power button to turn the laser tool OFF.



self-leveling mode

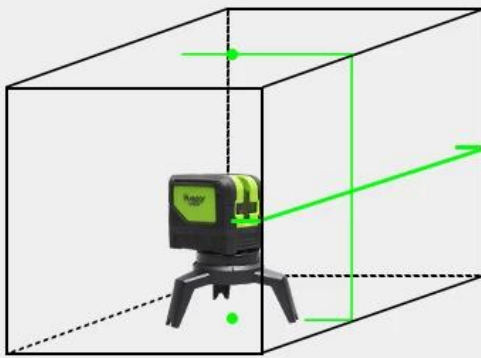

Self-level Available



Within 4 Degree

$\leq \pm 4^\circ$



Pendulum Unlocked



manual mode



Maintain The 90° Angles



Blinks Every 3 Seconds



Pendulum Locked

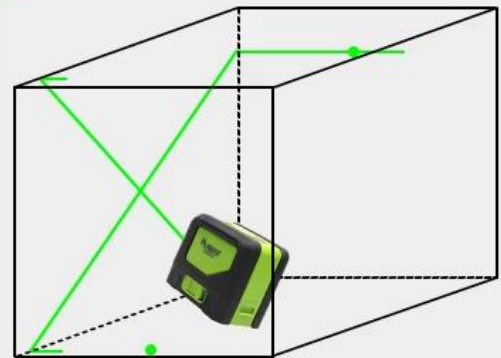





● PACKAGE INCLUDE

XEAST®



● TERMS OF TRADE

- 1) 付款条件: T / T, L / C, Paypal, MoneyGram 30% 预付款, 70% 发货前付清
- 2) 运输方式: 海运, 空运, 快递 (DHL, TNT, UPS, FEDEX, EMS, SPSR, 139 等) LCL, FCL
- 3) 交货地点: 工厂, 仓库, 港口, 机场, 火车站, 码头, 客户指定地点

● COMPANY INFORMATIONS



SALES TEAM



WOKRSHOP

